

WISI LR 94 2x01

RF Overlay Receiver for FTTH applications



Description

The LR 94 2x01 is an RF Overlay receiver with a high output level that supports SDU and MDU in-house distribution architectures. The wide downstream level range covers the input side while the built-in AGC keeps the RF level constant. Its compact design requires a minimum amount of space.

At a glance:

- Downstream up to 1.2 GHz
- Compact housing for indoor deployment (IP20)
- Optical ALC for regulated output levels
- Switchable output power High / Low
- RF test port for the output signal

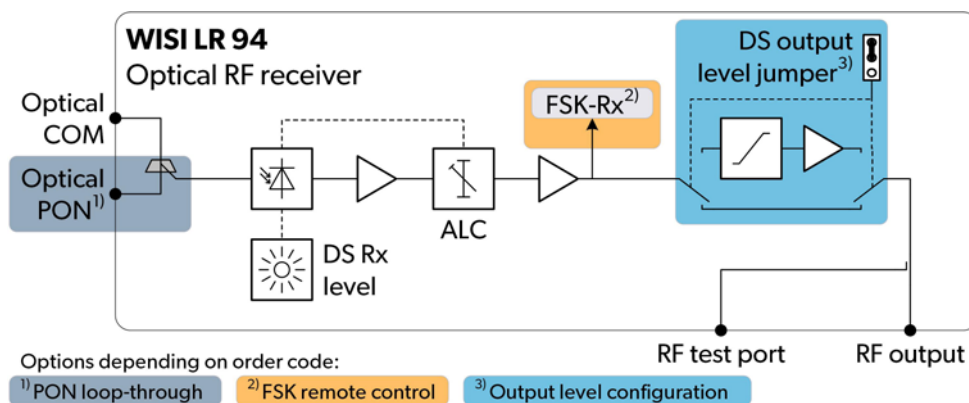

Technical data	
Downstream	
Wavelength	1260...1610 nm (LR94xx0xx)
CATV wavelength	1540...1560 nm (LR94xxZxx)
Optical return loss	>40 dB
Nominal Output level (@ 4% OMI)	80 dBμV (flat)/ 97 dBμV (5 dB slope)
Maximum channel load (EN60728-3-1, BER <1 exp-9)	according to OMI table
Optical input power	-6...+3 dBm
Frequency range	47...1218 MHz
Return loss	>18 dB (-1dB/Octave, min. 14 dB)
Frequency Response (O-E)	±1 dB
Equivalent input noise density	<4 pA/√Hz
Test point	-20 dB
PON-WDM (optional)	
PON wavelengths	1260...1500 nm & 1570...1620 nm
Insertion loss	max. 1 dB
Isolation COM -> PON	>35 dB
Isolation COM -> RF / PON -> RF	>20 dB
Connectors	
SC/APC connectors	1/2 pcs. (Simplex), (2 pcs. if WDM Filter incl.)
LC/APC connector	1 pcs. (Duplex)
F-connectors	2 pcs. (RF output, test port)
General data	
Supply voltage	230 V AC (50/60 Hz)
Power consumption	max. 4 W
Dimensions (width x height x depth)	163 x 91 x 50 mm
Ambient temperature	-10...+50 °C
Protection class	IP 20
EMC	EN 50083-2
Impedance	75 Ω
Monitoring	
Optical RX Level LED colour	red: < -6 dBm / > +3 dBm; green: -6 dBm ... +3 dBm

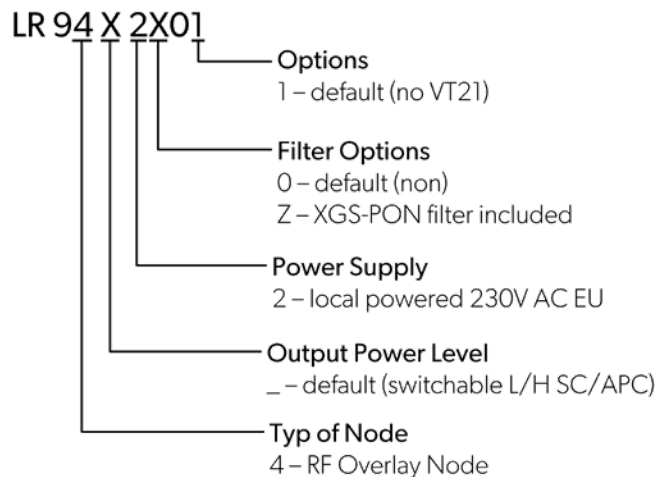

OMI table			
Output level low (dBμV / ch.)	Output level high (dBμV / ch.)	Optical modulation index / OMI (per ch.)	Maximum number of RF channels (approx.)
76	93	2,5 %	129
77	94	2,8 %	103
78	95	3,2 %	82
79	96	3,5 %	65
80	97	4,0 %	51
81	98	4,5 %	41
82	99	5,0 %	32